

« - 11: = » -
« - 11: ». – 2015. – .1, .2. - .268-272

-

• ” (• •
• •
,
, • .) - ,
•

6
() (1-). 2-
()
() [1].
1- 2-

0,5
,) (,
()

. [2]

« »

» 2012 « [3].

-
-

;

;

()
 -10/6
 () ()
 -6/10
 ()
 (2-) . - 25000
 -6/10
 .[3]

1

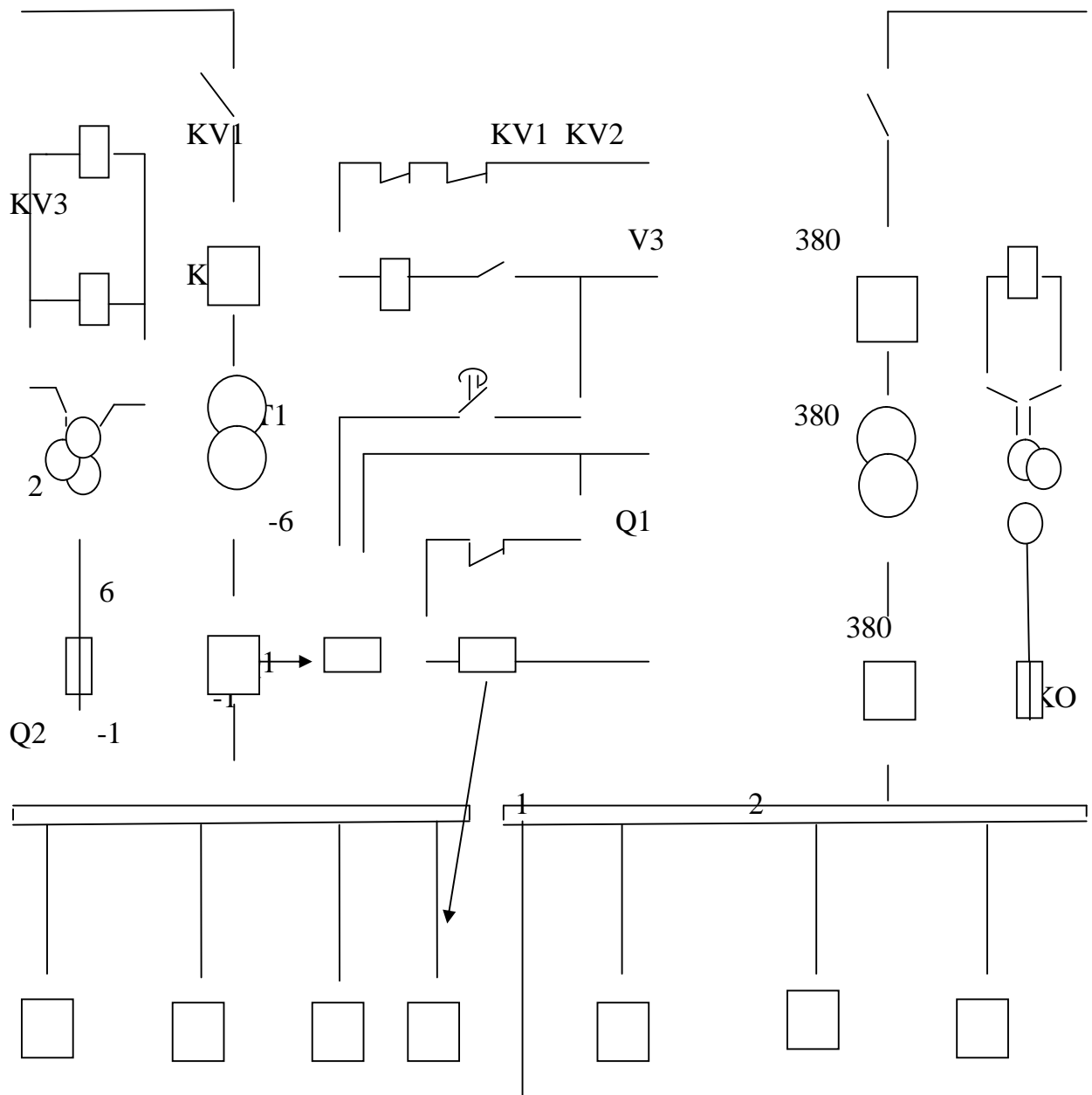



6

1-

-



6

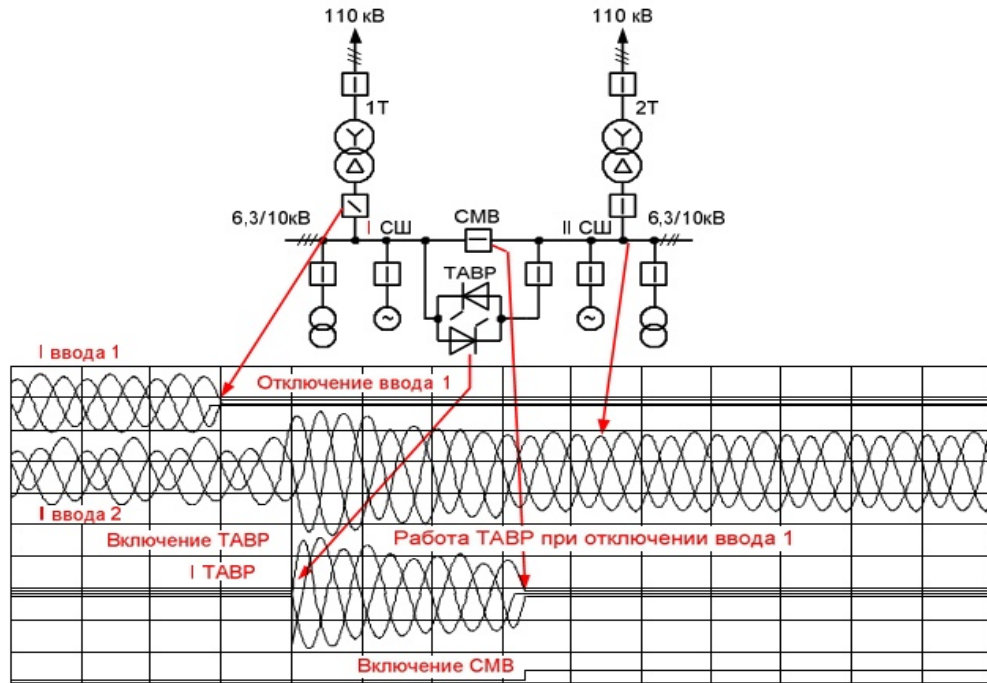

2- - -10/6

- 6/10

- 10/6

3-

- 6/10

25000

()

6/10

()

(-)

.[3]

- 10/6

() .
 () . ()
 ,
 .
 USB .
 . -
 . [3]

1- - -10/6 -

1	2
,	50
10	10
,	12
10	7,2
6,34	8,0
(0,1),	
1-	
- (40
), ,	
-	100 000
, ,	
	SPAC, SEPAM, 3
-	,
-	, 3-
-	220/380 3-
-	200-
-	50-
,	

	20
- 15150-69	4
	20 14254-80
	- () 15150-69

:

« »- « »-
- , , . . . -
() .
() ;
(20) .

1. Aleksandrov A.I., J. Electronics & Electrical Engineering// Energetics - 2007.-
Volume (30). - .15-17,

2. . . , . . , . . , . . , «
». 2006. - 55-
57.[205]

3. . . , 6 . , «
». 2005.
- 20-22.[45]